

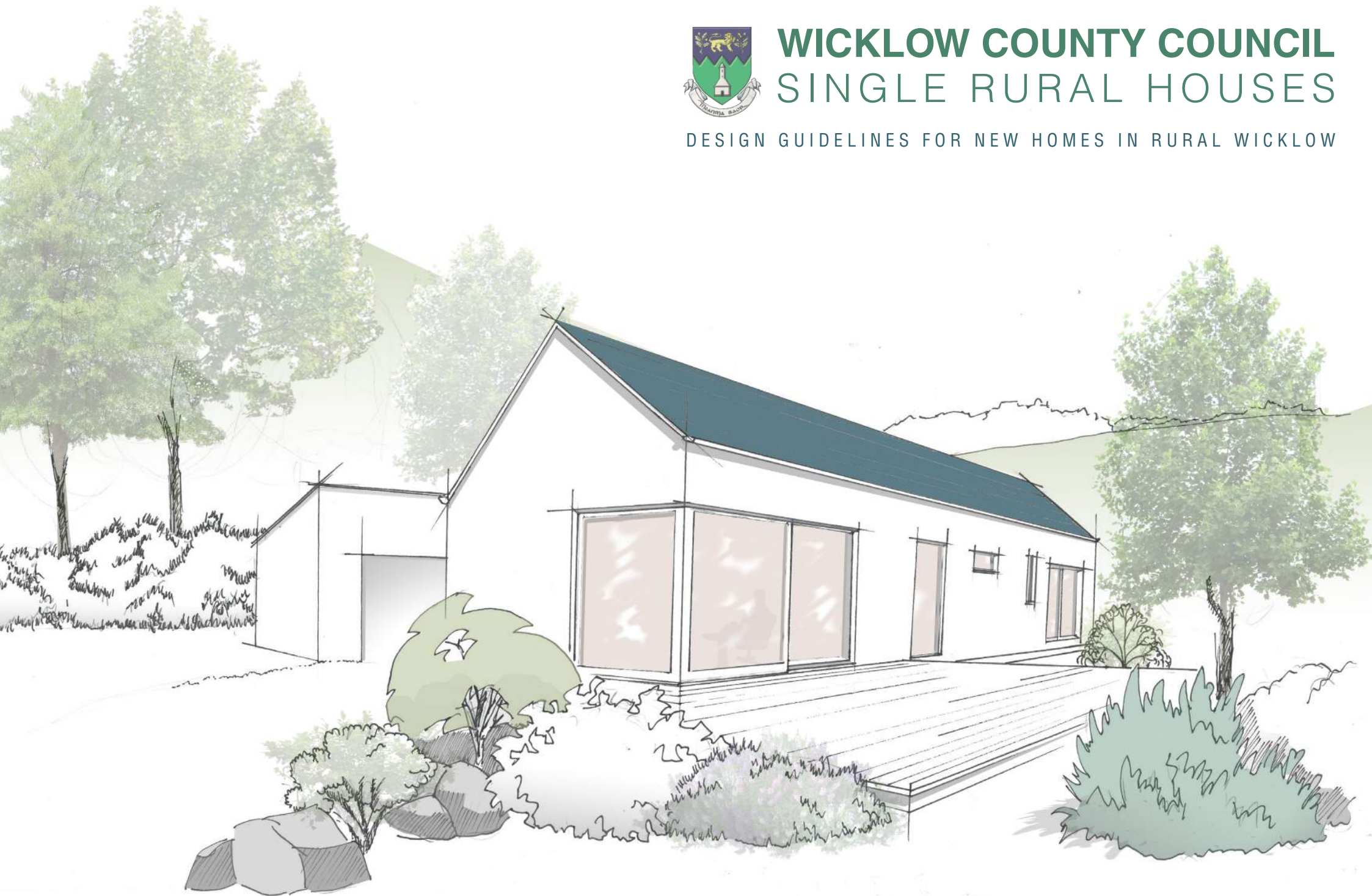

WICKLOW COUNTY COUNCIL SINGLE RURAL HOUSES

DESIGN GUIDELINES FOR NEW HOMES IN RURAL WICKLOW





FOREWORD

This rural house design guide is intended to provide guidance to prospective developers of single dwellings in rural Wicklow. The following information and illustrations are non-prescriptive and are general in nature; the guide does not provide a definitive 'list' of all dwelling styles or features that may be granted permission; nor does it set out all planning considerations relevant to an application for a single rural house. It is intended to be utilised as a tool to assist potential applicants, architects, landscape architects and planning agents in the areas of site selection, house positioning, layout and house design.

As this guide is principally concerned with house design and layout issues, it does not provide guidance on on-site effluent disposal systems, water supply and entrance / road safety requirements.

With respect to on-site water services, developments will be required to comply with Wicklow County Council's "Policy for wastewater treatment and disposal systems for single houses (PE \leq 10)" which is available on the County Council's website and the applicable Drinking Water Regulations.

While this guide will address the aesthetics of entrance design, with respect to road safety standards, such as required sightlines, the most up to date road design manuals should be consulted.

CONTENTS



01 **SITE SELECTION**
Choosing where to build

02 **HOUSE POSITION & SITING**
Principles of good siting,
managing contours, rural infill

03 **HOUSE DESIGN**
Principles of good rural design,
scale, height, format, roof style,
dormers, windows & materials

04 **ANCILLARIES**
Boundaries, entrance design,
landscaping, outbuildings,
energy efficiency, extensions &
conversions

05 **APPENDICES**
Acknowledgements, Photo &
Design accreditation

A wide-angle landscape photograph showing a golden field in the foreground, rolling green hills in the middle ground, and a blue sky with large white clouds. The scene is captured from a low angle, emphasizing the vastness of the landscape.

INTRODUCTION

The overriding objective when considering building a house in rural Wicklow is to protect and conserve the beautiful landscape and environment we have inherited from other generations. The key to this is site selection and site layout, and the house should be absorbed as much as possible by the landscape, and this should be helped by landscaping. The house type and design also has an important impact. Thus houses that do not fit into the landscape due to their scale, unusual design features, colour, or materials that are non-traditional to that particular area will tend to stand out in close up and far distant views. Likewise boundary features and site entrances can add to the visual intrusion, and even landscaping with non-native species will cause a development to stick out in the general landscape.

The following paragraphs are to give guidance, but should always be read in the context that the overall design and siting should leave as small a trace on the landscape as possible.

01 SITE SELECTION

CHOOSING WHERE TO BUILD



All new developments will be required to be sited in such a way that allows them to blend into the landscape and not form an overly visible or strident feature on the landscape. Therefore site selection is the most critical step in rural house design. Some sites, for a variety of reasons, may not be suitable for house building and even a well considered and designed house may not be permissible.

Where no site choice is available, it cannot be assumed that permission will be granted solely on the grounds that the applicant has a bona fide necessity to live at that location.

When selecting a site, the following criteria must be considered:

- The openness and visibility of the site in the surrounding landscape, the sensitivity or vulnerability of the landscape to new development and the existence of protected views or prospects in the area. In these regards, prominent and exposed sites should be avoided as well as those that would impinge on a protected landscape or view. Applications in an Area of Outstanding Natural Beauty will be required to be accompanied by a Visual Impact Assessment (more information on VIA is found in pages to follow);

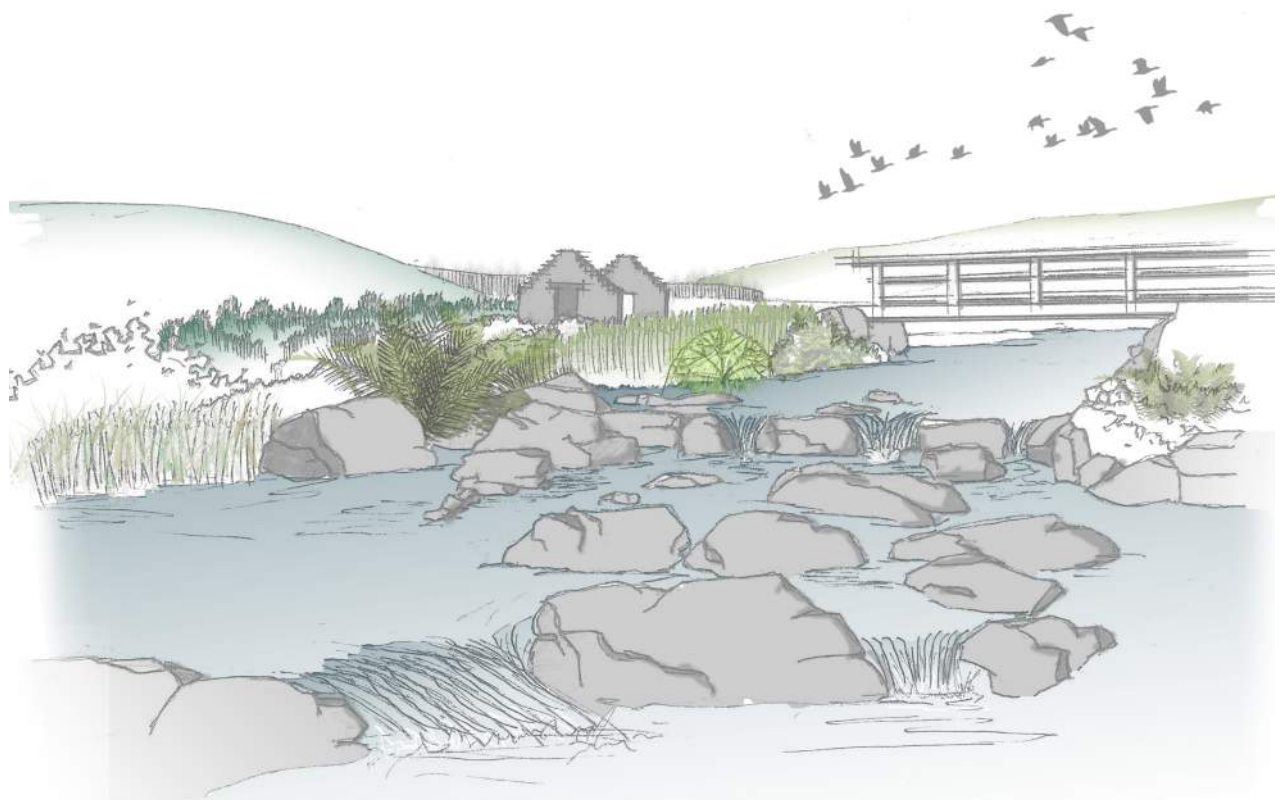

Area of Outstanding Natural Beauty, Glendasan mining village, Wicklow

- Impacts on any other properties or dwellings – cognisance must be taken of potential impacts on existing proximate dwellings, particularly overlooking and overshadowing;

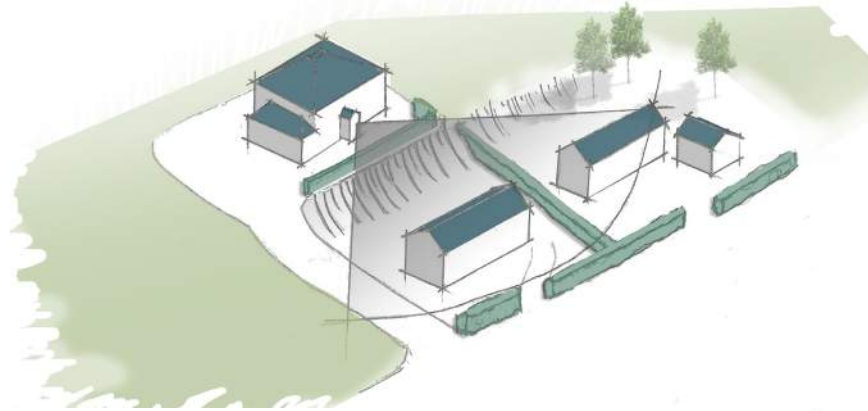

- The possibility of clustering the new development with other houses or manmade structures; however, care needs to be taken to avoid over-development in any location or ‘ribbon development’ ;



Avoid ribbon development, an almost continuous road frontage type development, where 5 or more houses exist on any one side of a given 250 metres of road frontage.

- The existence of heritage features on or near the site, such as protected habitats or archaeological features. A buffer zone between such features and any new development may be required, the extent of which will depend of the feature to be protected;



Avoid building in prominent open areas, or areas of protected views or landscapes.

*  = Undesirable design approach
 = Recommended design approach



Proposals within an Area of Outstanding Natural Beauty may be required to be accompanied by a Visual Impact Assessment. In other landscape areas, the planning authority may require the submission of a Visual Impact Assessment, where a proposed development is likely to affect a particularly scenic or sensitive landscape. A Visual Impact Assessment (VIA) should include the following:

- An evaluation of the visibility and the prominence of the proposed development in its immediate environs and in the wider landscape; this assessment should include the erection of profiles of the house and / or the production of photomontages of the proposed development from clearly identified vantage points
- An evaluation of impacts on any listed views / prospects and an assessment of vegetation / land cover type in the area (with particular regard to commercial forestry plantations which may be felled thus altering character / visibility).

02 HOUSE POSITION & SITING

READING THE LANDSCAPE



New houses shall be suitably positioned on site to make maximum use of screening available either from the land form itself or from existing tree cover. Positioning in a sheltered location not only aids visual integration in the landscape, but also provides benefits to the house in terms of protection from the elements and improved privacy.

PRINCIPLES OF GOOD SITING:

Houses shall not be above a ridgeline or so positioned to break the skyline or to appear highly visible or dominant in the landscape;



Houses located in the middle of sites / fields, distant from boundaries will not be considered acceptable – houses should be 'tucked into' existing field boundaries;



The house should be positioned to maximise daylight and solar gain – 30% energy savings can be achieved if the house is oriented within 15° of south, provided its main living areas are arranged to avail of passive solar gains (refer to the 'Development & Design Standards' of the Wicklow County Development Plan);

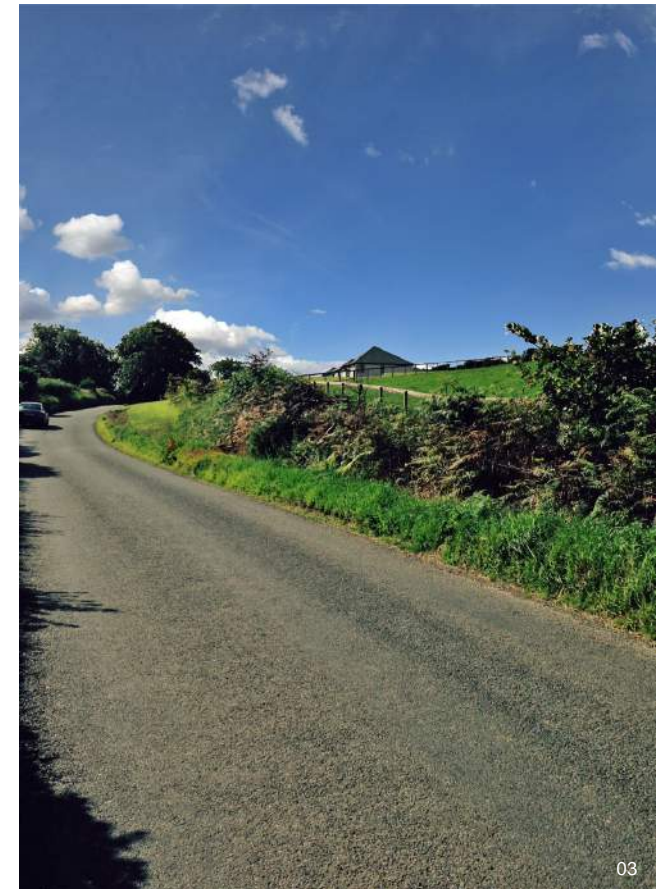
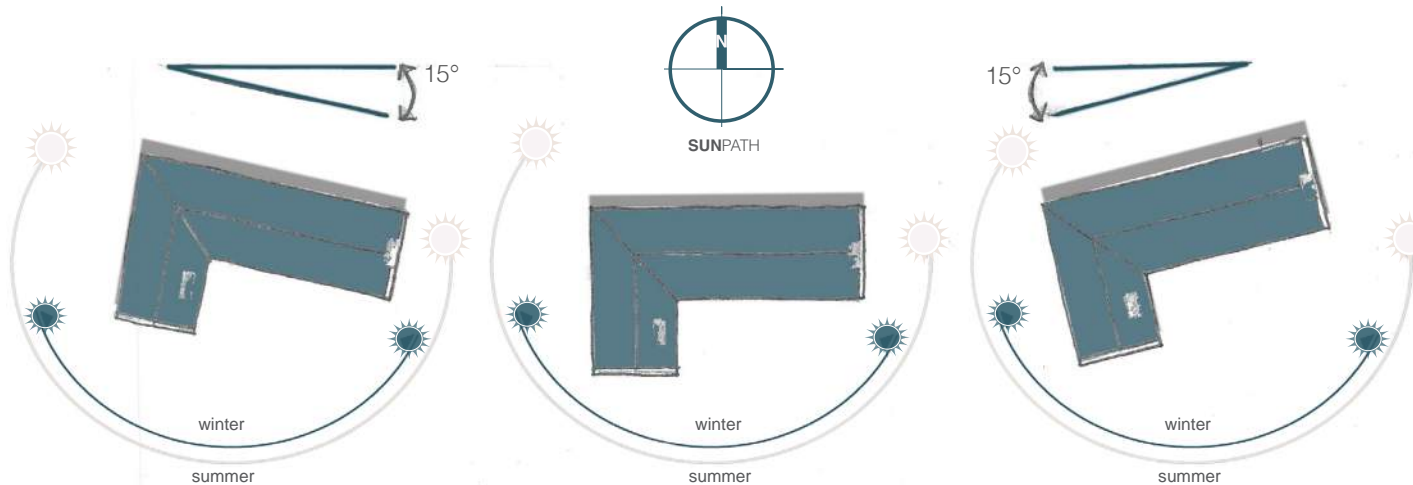

Avoid houses breaking the skyline.



Passive design angled towards the sun with large openings to maximise solar gain.

03

04

MANAGING CONTOURS

On sloping sites, houses will normally be required to be built into the slope of the site, so that the finished floor level of the house is not more than 0.15m above the existing ground level to the front of the house. However, deep excavations should also be avoided as these in themselves can cause a scar on the landscape. Where steeply sloping sites cannot be avoided, design solutions must be considered to minimise the impact, including for example the use of stepped or split level housing.

IMAGES OF MANAGING CONTOURS:

A

On sloping sites, the principal axis of the house should ideally have stepped floor levels reflecting the contours.

B

Where excavation cannot be avoided, narrow plan houses with minimised cut and fill are recommended. Excavated soil can be redistributed as naturalistic landscape mounds.

C

Avoid deep plan over scaled houses set on large platforms with urban planting schemes.

D

Avoid unsuitable dwelling styles with parking to the front. Absence of natural planting with excavated soil not graded to suit site contours.

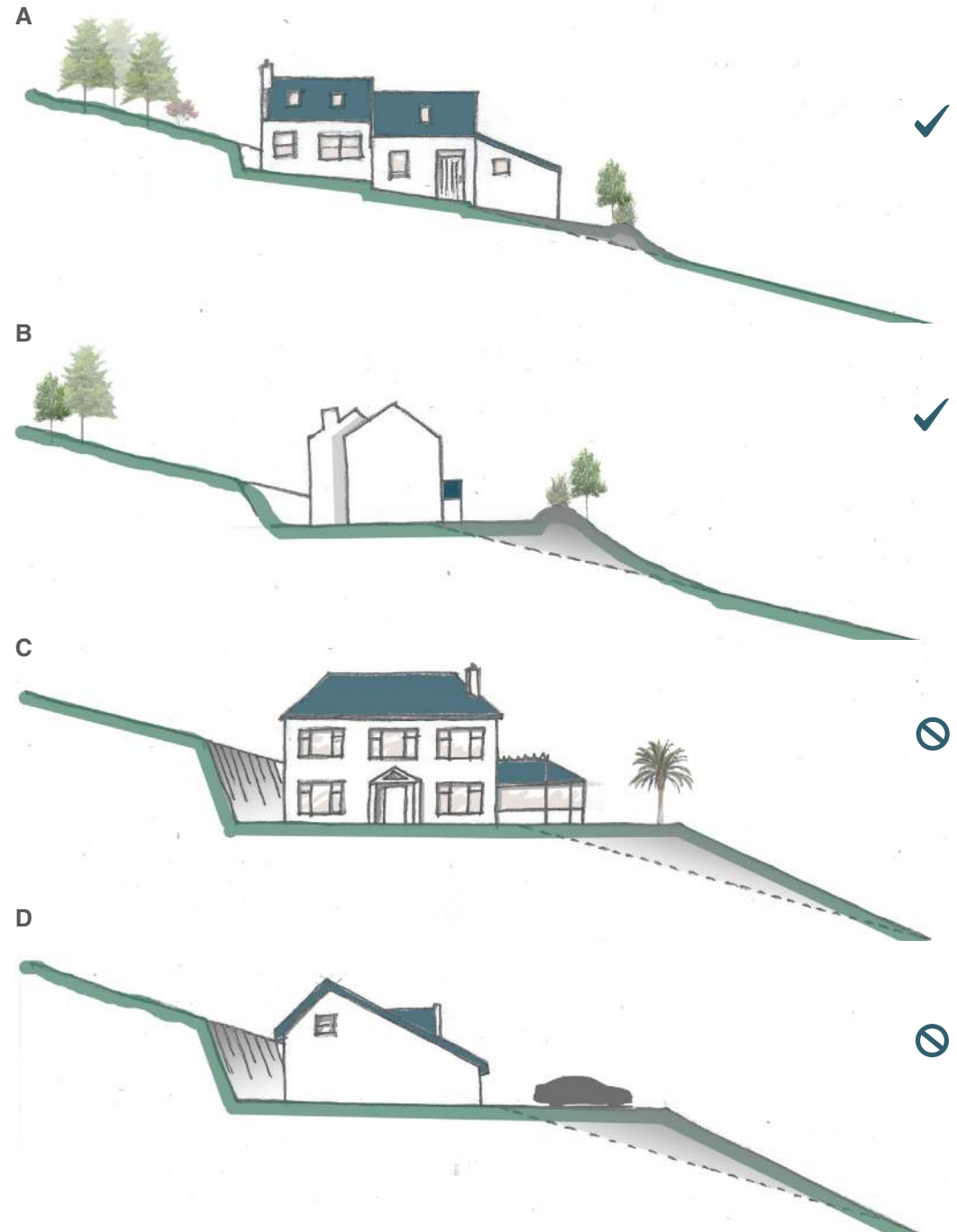

RURAL INFILL



Where the proposed development site currently forms part of the site of an existing dwelling (i.e. it is proposed to subdivide an existing plot), the following considerations must be taken on board:

- A** The site must be large enough to comfortably accommodate the existing and additional house(s) and their associated facilities such as independent gardens, car parking, effluent disposal facilities etc.
- B**
 - i) The new house(s) should be so positioned on site to have a 'relationship' with the existing structures.
 - ii) In this regard, the end result should not be two (or more) distinct houses sitting at the opposite ends of the same site or a new house directly behind an existing one.
 - iii) Consideration must be given to clustering or the creation of courtyard type development, reminiscent of a vernacular farmstead layout.
- C** The new house should not result in adverse impacts on the amenities (e.g privacy, light) of adjacent properties.

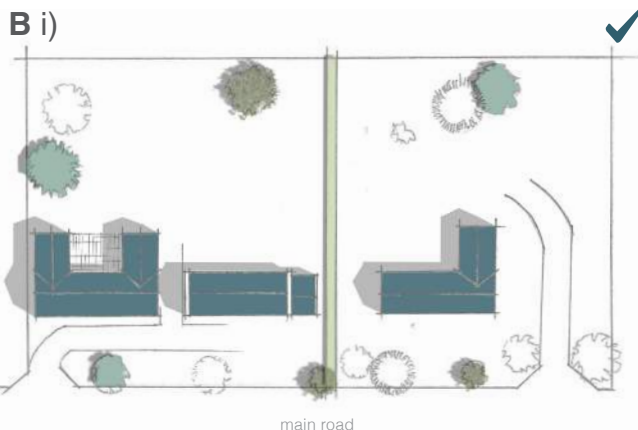
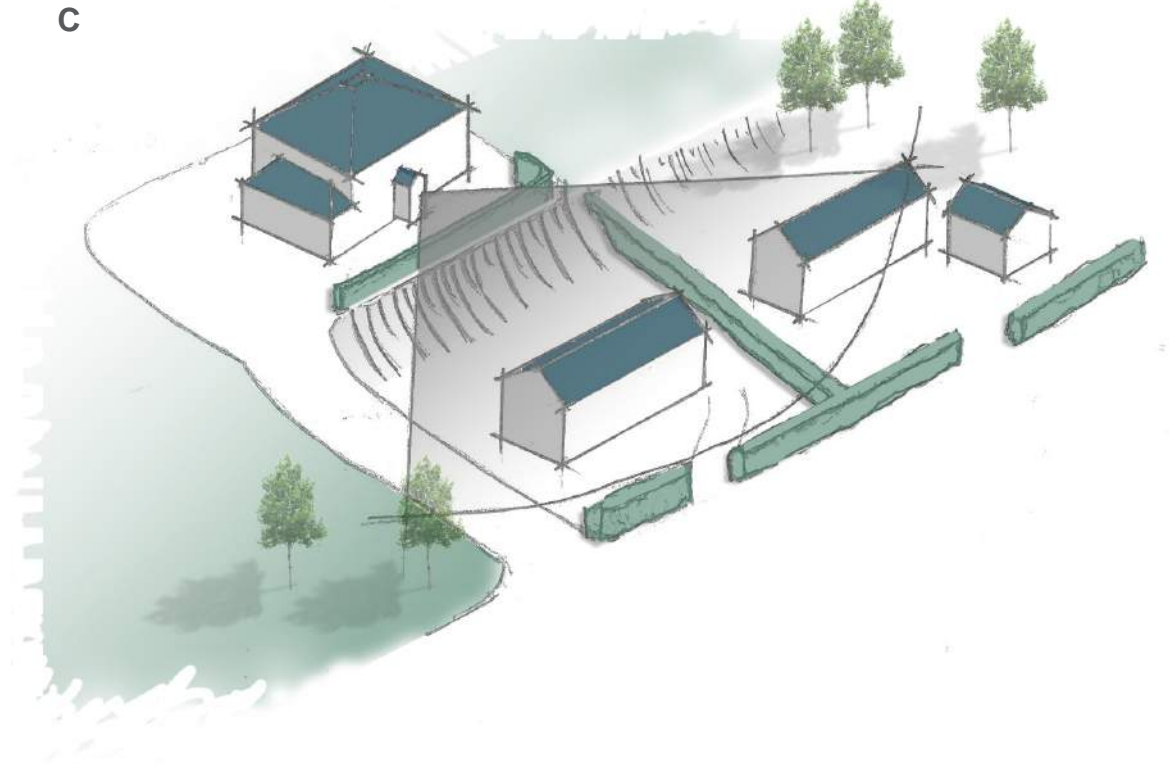

main road

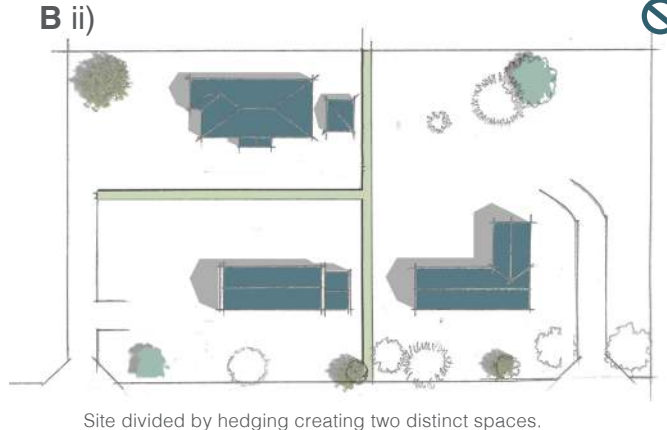

Site divided by hedging creating two distinct spaces.

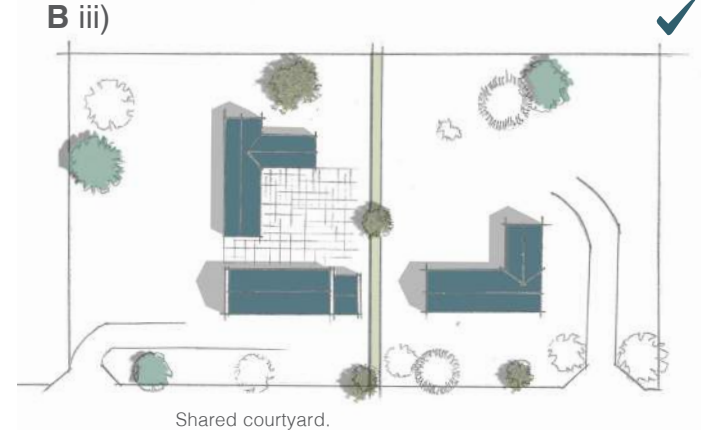

Shared courtyard.



03 HOUSE DESIGN

DESIGN CONSIDERATIONS





High quality design will be required for all sites and the design of any house will be required to be developed taking cognisance of the site location and characteristics and prevalent style of dwellings in the area; however, this does not mean that a poor house design will be considered because similar inappropriate designs have been permitted in the same area in the past. Designs lifted from another site and from a formulaic ‘pattern book’ will not be accepted, nor will poor historical imitations.

Designs should reflect traditional rural house design form and concepts, but contemporary interpretations of traditional styles are acceptable where the site can accommodate and suitably absorb the design.

Design proposals should respect the characteristics of the site and its environs by working with, rather than against natural features, such as boundaries, contours and flora.

DWELLING SCALE

As a result of modern demands for larger houses and Building Regulations which require higher ceiling height, rural dwellings have become larger in scale. However, insufficient care has been taken in mitigating the impact of this larger scale and many new dwellings appear very out of scale with surrounding traditional buildings and with the landscape itself. In this regard, dwellings should be sized according to the current and future needs of the occupant.

A large dwelling will require a large site and needs to be set within a 'large landscape'. An area characterised by small field patterns and low level vegetation is unlikely to be suitable for a large dwelling which will dominate the area. However, where existing vegetation is mature and abundant and the views are long, there may be scope for a larger dwelling.

Consideration must also be paid to other dwellings that may be in close proximity to the proposed development site. A new dwelling that does not respect the existing scale and vernacular in an area or results in impacts on surrounding dwellings with regard to overlooking or overshadowing will not be permitted.

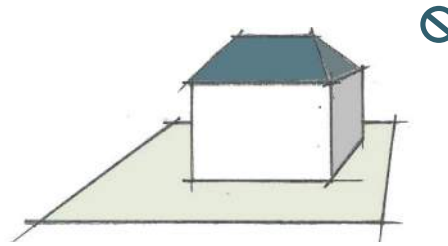

This house's scale is disproportionate to the site

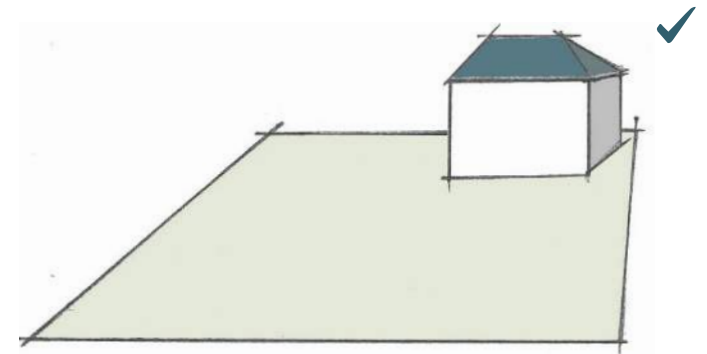

This house is appropriately scaled for the site



Consider the scale, mass, external finishes and context of the proposed dwelling and its effect on dwellings in close proximity.



Appropriately scaled houses with simple dominant form near Arklow, County Wicklow.

PRINCIPLES OF GOOD RURAL DESIGN



AVOID

- Large excavation to accommodate house.
- Absence of natural landscaping. Exposing the site to the elements increasing weathering and heat loss.
- Completely circling the house with hard surfaced areas / paths – where possible, planting should be brought right up to the house.
- Suburban house designs and planting schemes.



DO

- Locate house on flatter ground on the site, reducing excavation.
- Use internal floor changes to absorb contours of the site.
- Tuck house into the site boundary allowing the landscape to protect from natural elements.
- Localised planting close to the house to absorb the development into the local landscape.



Bespoke design responding to site contours in an innovative manner.



Contemporary extension to rural cottage adapting site contours into the design.



Traditional-style cottage using planting as protection. Hollywood, County Wicklow

DWELLING HEIGHT

The majority of new rural dwellings in County Wicklow in the last 20 years have been single storey or dormer bungalows. In many cases, the sensitivity of the landscape allows only for a single storey dwelling, but where additional height can be absorbed, the majority of applicants have proposed a dormer style rather than a 2-storey dwelling often in the belief that the passage through the planning system would be easier with a dormer bungalow than a 2-storey house. Well designed dormer bungalows are hard to achieve, as the style of windows and roof mass often distort the shape of the house and form incongruous features. Generally, a high quality 2-storey house will be preferred to a lower quality dormer bungalow, the key parameters being the ability of the site and landscape to absorb the house.

DWELLING FORM/SHAPE

The key requirement for rural houses is that they be absorbed by the landscape. Dwellings should thus blend in and not dominate the local landscape, or stick out by reason of scale, form, or detail. Dwellings should be simple in form and shape and an excessive number of block shapes and heights, roof pitches, additions, wings, protruding windows (such as bay windows), porches, conservatories etc should be avoided. The main body of the house should be the dominant element and be clearly distinguishable, and if necessary, one or a number of smaller, suitably designed projections attached to the main house may be provided to break up the overall mass of the structure.

‘Deep plan’ houses (i.e. houses that are two rooms ‘deep’ with a central dividing corridor) should be avoided, as this format overly constrains the options for the format, design, roof style and glazing layout of the house and also results in poor use of natural lighting.

While symmetry is not required, houses should be well ‘balanced’. This will mean that any projections to the main body of the house will require to be sensitively designed and located and not cause the house to look ‘lop-sided’.

NARROW PLAN



This design encourages a good ratio of glass to masonry, efficient light penetration, potential extensions and a 30% reduction in heating costs from solar gain.

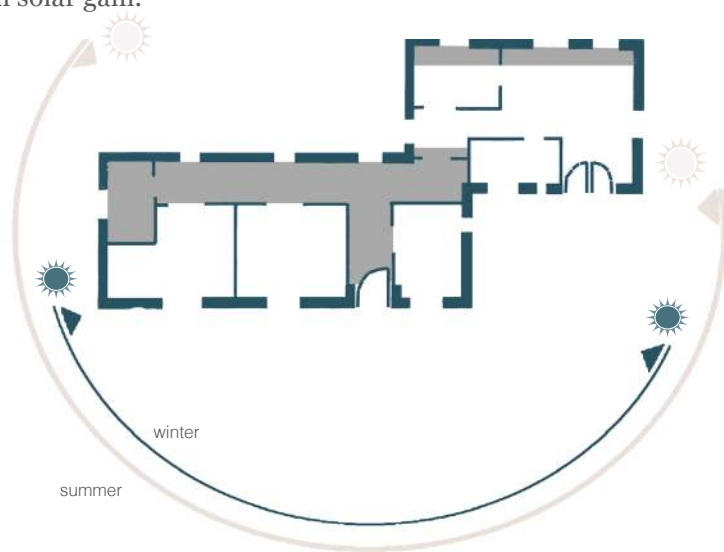

DOUBLE DEEP PLAN



Only 50% of the house can benefit from solar gain and light penetration.

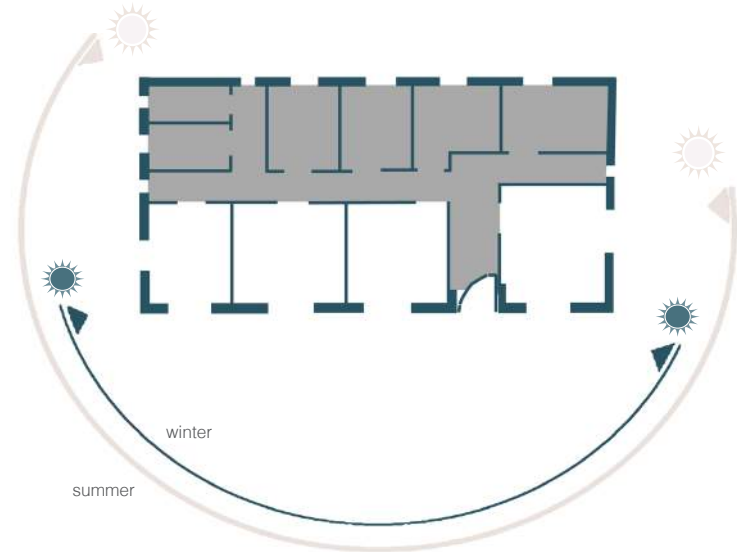

Traditional flat-fronted narrow design form with naturalised planting absorbing the design.



Avoid double deep dormer designs with PVC clad dormer windows and suburban gardens.





DWELLING SHAPE EXAMPLES

Recommended dwelling shapes.

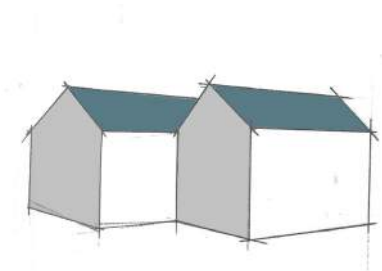

Doubled and slipped

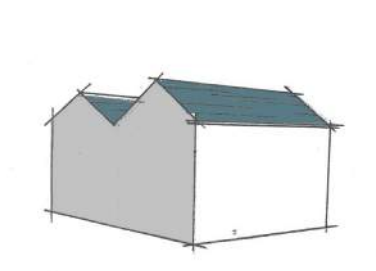

Valley roof

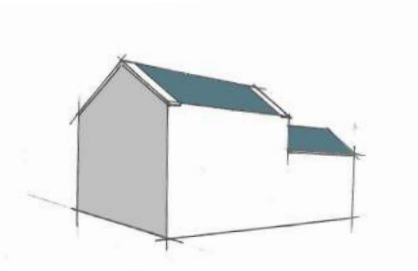

Long 2 Storey

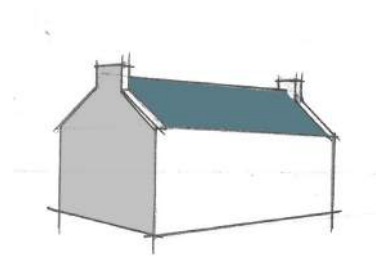

Simple gable roof

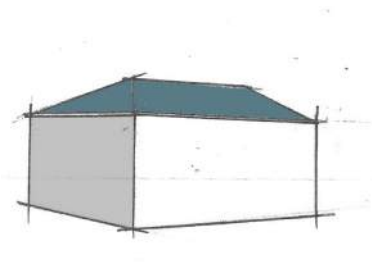

Narrow plan hipped roof

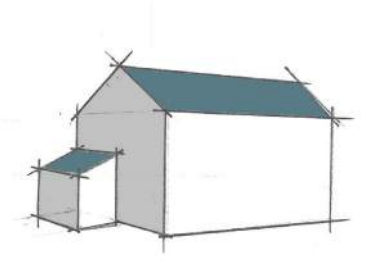

Simple gable roof and tin/slate lean to

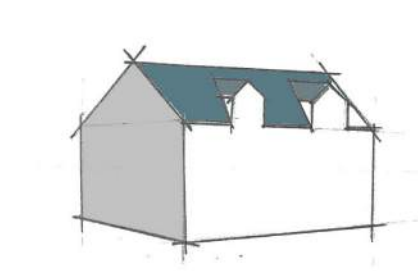

Dormer windows extending upwards out of main walls

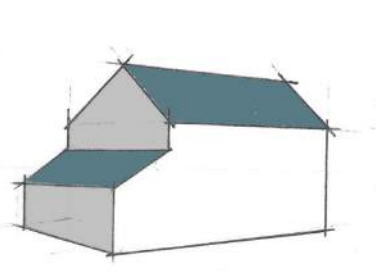

Lean to

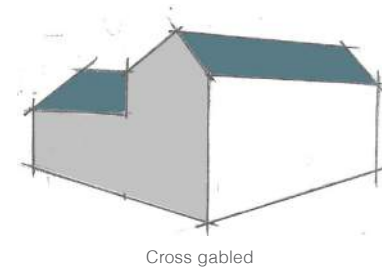

Cross gabled

Generally, the following characteristics should be integrated into a new dwelling

- low eaves
- 35-55 degree roof pitch
- sturdy and solid
- narrow plan
- vertical emphasis to gables
- flat fronted



DWELLING SHAPE EXAMPLES

Avoid suburban dwelling forms; awkward scales, wide gables, eaves over 55°, over-sails, PVC cladding, ornate finishings.

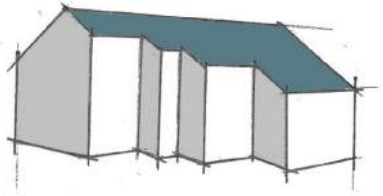

Eroded roof



Ornate porch/pillars

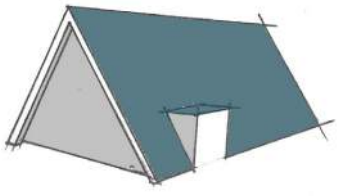

Steep Swiss roof

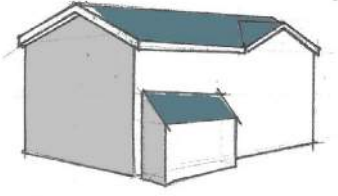

Half porch type

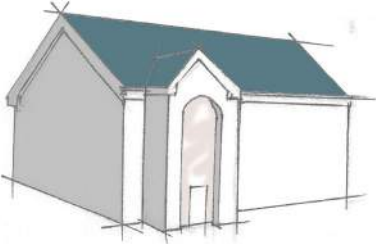

Large glass portico

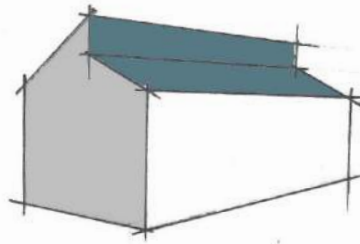

Clerestory roof

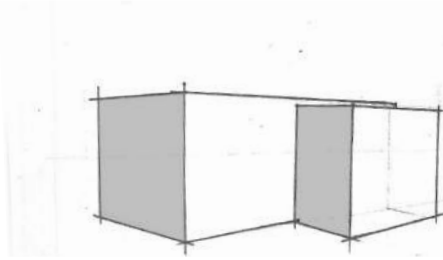

Flat roof unless carefully designed

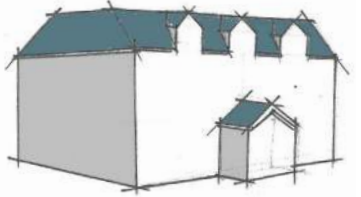

Mansard roof

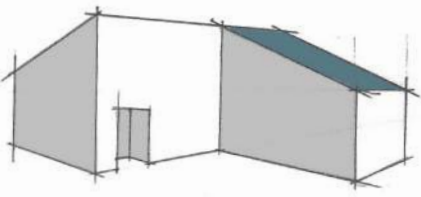

Salt box roof

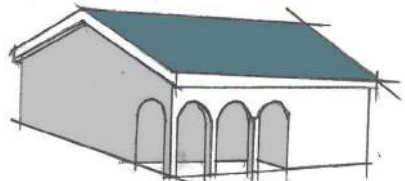

Recessed porch



Projecting twin gables & bay windows

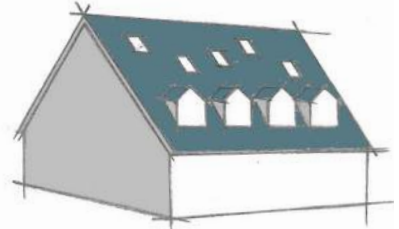

Large roof to wall ratio, excessive amount of dormers and skylights

ROOF STYLE

House formats should be avoided that require excessive roofing – i.e. the ratio of ‘roof to wall’ needs careful consideration. Where an appropriate building format is used, this problem should not arise; however, deep plan bungalows or bungalows with large dormer spaces tend to have excessively large roofs and therefore appear ‘unbalanced’. This should be addressed by breaking up the roof mass, for example, by creating a ‘valley roof’ that will effectively halve the size of the roof.

Modern houses tend to include roof edges that significantly ‘oversail’ the external walls, a feature which gives the roof more ‘dominance’ over the main structure of the house, thereby weakening its appearance and rendering the appearance out of keeping with traditional Irish rural house features. Eaves overhang should be minimised or mitigated by good design.

To make new rural houses as unobtrusive as possible and in keeping with traditional rural houses, roofs will normally be required to be tiled or slated in dark colours such as blue / black or dark brown.

DORMER STYLE

Where a dormer style house is selected as the best option, this should be in the format of a 1 1/2 storey dwelling, with dormer windows extending upwards out of the main walls of the house, rather than the provision of a number of ‘break-through’ type dormer windows, as these tend to require a larger mass of roof. The use of rooflights to mid-roof dormers will be preferred and these should be so constructed to sit flush with the roof slates.

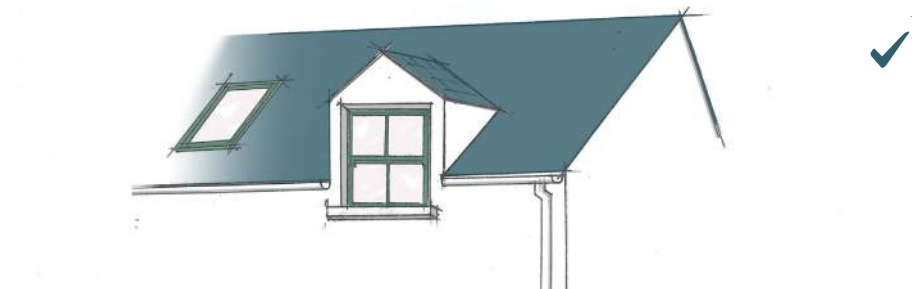

Simple eaves with dormer window extended out of the facade in matching render. Symmetrical rooflights recommended to reduced building scale.

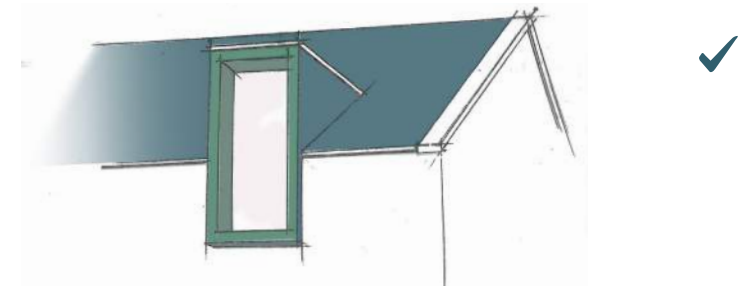

Where appropriate, or on screened facades, well scaled contemporary dormers may be acceptable.

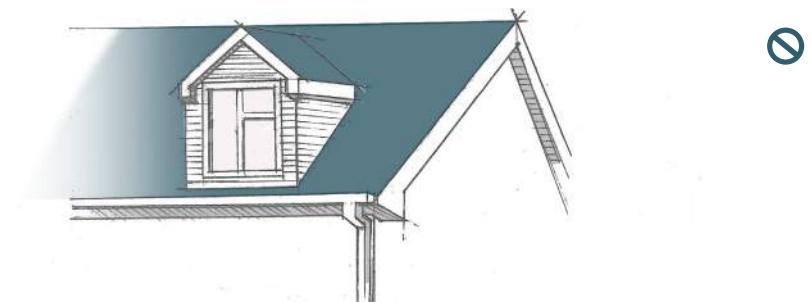

Avoid box verges and eaves and the use of cladding. Ideally the dormer window should be connected to the facade and not protruding from the roof.

WINDOWS & DOORS

Careful consideration must be given to the 'solid-to-void' relationship on a dwelling façade i.e. the relationship of solid wall to openings. The arrangement of openings should be kept simple and should be normally of the same size and style across the entire façade. Openings should be placed around the 'central' axis of the façade and should normally be symmetrical unless a high quality design allows otherwise.

Windows should generally be vertical in emphasis and in proportion to the rest of the house. Oversized feature windows to certain living spaces are permissible, but only where the length to width ratio is appropriate and the integrity of the overall design and balance of the house is not compromised.

Over-elaborate door styles should be avoided e.g. overly glazed panels or fan lights, as should large and fussy porches or canopies, particularly those including mock classical detailing and pillars.

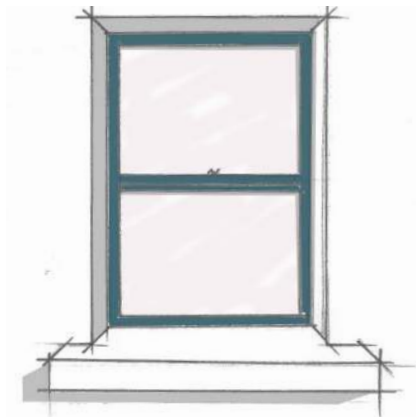

Sash window.



Drop sill with vertical dividers.

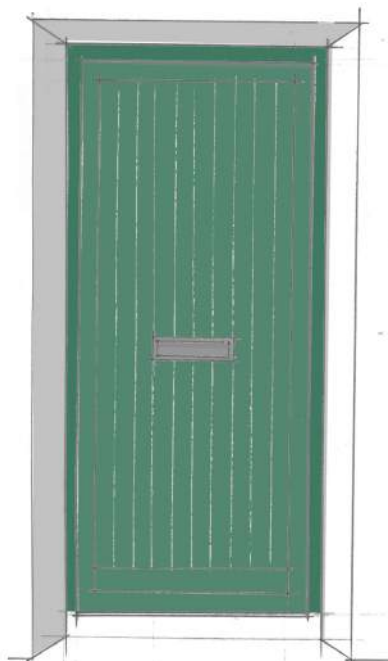

Timber door with painted finish.



Modern door in traditional vernacular.

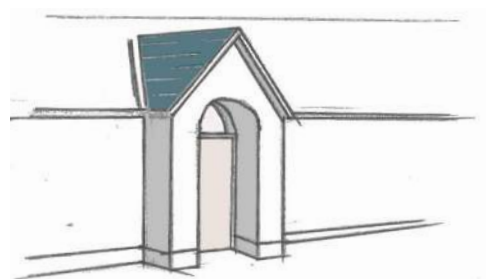

Examples of porch layouts using the same material as the dwelling.



Simple matching openings across the entire facade complete with a porch of the same finish. Dunlavin, County Wicklow.

MATERIALS

Rural houses in County Wicklow are typically rendered and painted white / off white and this will be the normal finish required for new rural houses. Dashing with a coloured chip / pebble will not be permitted.

Brick, timber and metal finishes are not common and have only appeared in the last 30 years. The use of stone in domestic scale buildings would have been uncommon, although there are some localised exceptions, for example, areas surrounding quarries e.g. Ballyknockan. New houses will be required to utilise finishes common to and suited to the area. However, in locations where alternatives to painted render are typical or where a site is highly screened, alternative materials may be considered.

The use at an appropriate scale of timber, metal or stone features on a mainly rendered house to provide visual interest is welcomed, subject to correct positioning of the feature element and the use of the highest quality and appropriate materials. Brick will not normally be considered in any rural location but as set out above, where the site is well screened or very unobtrusive, flexibility in materials permitted will be afforded.

Required external pipework and cabling associated with modern technology should be subtly located and should be coloured or painted to allow it to blend in with the façade.

Ornate fascias, patterned metal work, reconstituted stone / cladding or pre-cast features shall not be permitted.



Rural vernacular roof and eaves.



Uncommon materials are adequately screened.



Considered balance of traditional and contemporary design.



04 ANCILLARIES



ENTRANCE DESIGN & DRIVEWAYS

New entrances shall be required to comply with current engineering safety standards with respect to sightlines and gradient and set back sufficiently to allow a car to pull off the road while a gate is being opened or closed.

The appearance of entrances shall be modest and suitable to the rural context and grandiose entrances with high wing walls, pillars and elaborate gates will not be permitted.

Where feasible, the location of the entrance and driveway should be offset from the location of the dwelling so as to retain the roadside boundary to the front of the house.

In highly scenic locations, applicants may be required to leave driveways only roughly surfaced to give a natural appearance.

All driveways shall provide sufficient area for car parking and turning on site. However, large hard paved car parking / turning areas, particularly to the front of the site, should be avoided.

Completely circling the house with hard surfaced areas / paths should be avoided – where possible, the garden should be brought right up to the house.

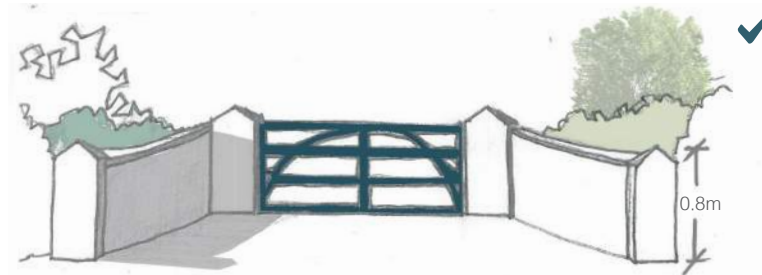

Example of a basic splayed entrance.

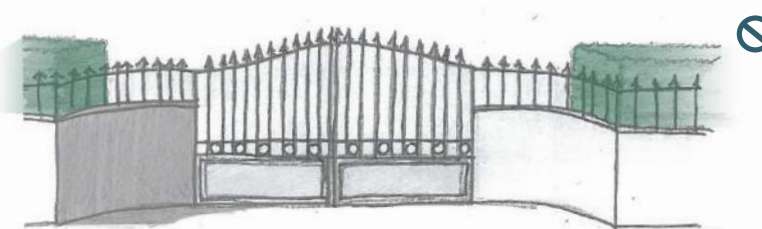
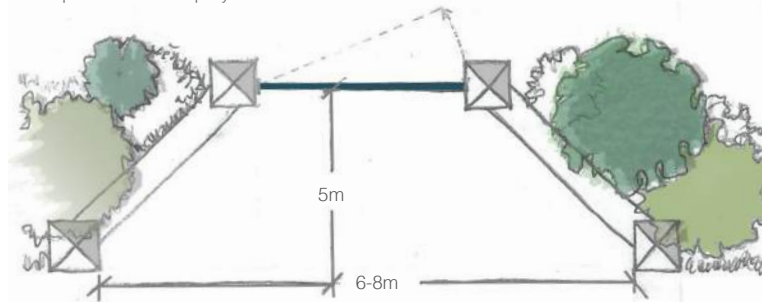

Avoid over-elaborate suburban entrances, precast walling, pillars and ornaments

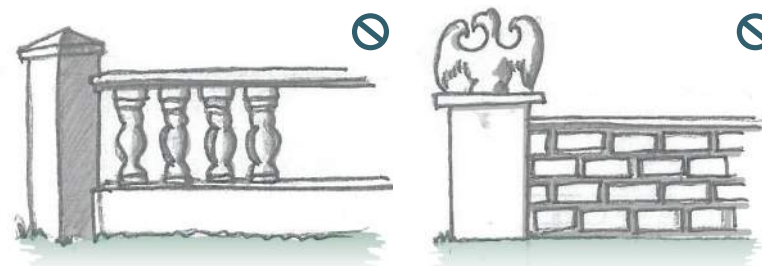

Naturalistic boundary planting and stone wall. Ballinaclesh, County Wicklow



Splayed timber fence entrance with mature trees. County Wicklow



New mounded entrance retaining existing planting and moat. County Wicklow



Timber fence with native planting and vernacular iron gate. County Wicklow

WALLS / BOUNDARIES

The design of walls and boundaries, particularly those along public road frontages, shall be suitable to the rural location. In the first instance, existing hedges and trees lining boundaries should be maintained. However, where they require to be removed for sightline or other reasons, they shall be replaced by a similar hedge of native species interspersed with suitable native trees. Long stretches of solid walls or railings will not be permitted, notwithstanding their perceived design quality. Sod-and-stone banks and dense hedges behind roadside drainage ditches are the prevalent traditional roadside boundary in County Wicklow – it will be a normal requirement of permission that such boundaries be provided or reinstated.

Existing side or rear boundaries, particularly mature field boundaries, should be maintained. Where new boundaries are required, they should not comprise solid walls or long straight, dense lines of evergreen trees. Instead clusters of trees at strategic locations around the site, which will appear more natural in time, will be preferred.



Contemporary design with well thought-out boundary to absorb the design into the landscape.

LANDSCAPING

All applicants for rural dwellings will be required to submit landscaping proposals. Landscaping schemes should normally be prepared by a landscape architect or other suitably qualified professional.

To assimilate the house into the landscape, additional naturalistic planting is recommended along boundaries or the provision of strategically located clusters within the site. A mixture of native hedge species (such as whitethorn, blackthorn, whitebeam, holly and gorse), deciduous and evergreen tree species should be used. Tree species planted shall include mountain ash, silver birch, willow, oak, sycamore, larch, spruce and pine. On exposed sites consider using species native to the immediate area to guarantee growth and shelter.

In visually problematic sites, the use of landscaping mounds may be required.

Landscaping including tree planting brought close to the house can reduce its impact and assist in integrating the house into the site. Planting should cut across the path of the wind and should be sited to make use of and improve natural shelter features such as ridges and rocky outcrops.

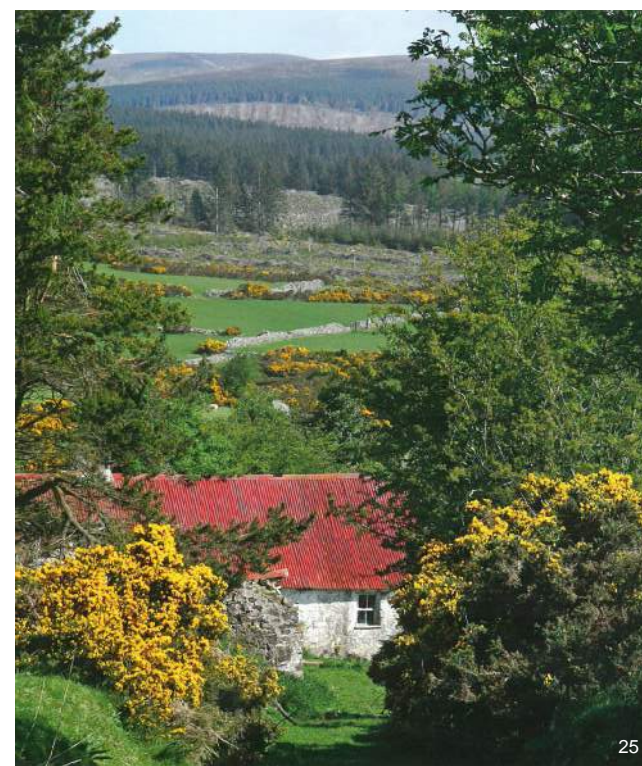



OUTBUILDINGS

The number of detached out-buildings on a rural site shall be kept to the minimum necessary and permission may be refused for excessive additional garages or stores where the need for same cannot be clearly demonstrated. Out-buildings should be located close to the main house and should be positioned to replicate a rural vernacular / farmyard format. Two-storey garages or garages in excess of 40sqm will not normally be permitted.



ENERGY EFFICIENCY

The planning authority will favourably consider proposals where attention has been paid to ensuring that the house is designed in a manner to ensure compliance with the highest energy efficiency standards. Guidance on this matter is set out in the Development and Design Standards of the Wicklow County Development Plan.



Dutch barn outbuilding conversion. County Wicklow.



EXTENSIONS TO EXISTING RURAL HOUSES

The design of an extension should be sympathetic to the existing house. This does not mean that it has to exactly match the existing style, height and finishes, but that it should complement the existing house and not look out of place.

A good extension is usually subservient to the main building i.e. extensions should be designed so that they look like extensions rather than a new house 'attached' to an old house. Extensions can reflect traditional aspects of the existing building, but contemporary extensions can also serve to complement the existing building.

There are no hard and fast rules about the size of an extension, but it will be necessary to ensure that:

- The extension respects the size of the existing house;
- The extension does not reduce the area of the garden to such a degree that it affects the usefulness of the garden;
- The site is big enough to accommodate the extension as well as all the other facilities that a house requires e.g. effluent disposal system, car-parking area etc.



Contemporary extensions to rural cottages in County Wicklow.



Use of a different material on the extension breaks up dwelling mass.



EXTENSION SHAPE EXAMPLES

Examples of some of the preferred extension shapes. They should not dominate the existing structure. Avoid flat roofed extensions unless a contemporary approach has been designed by a professional.

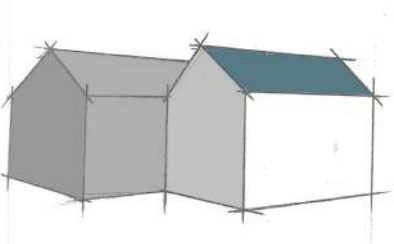

Doubled and slipped

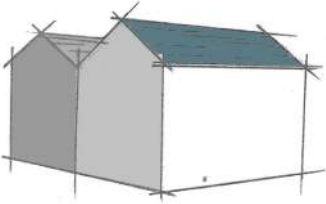

Valley roof

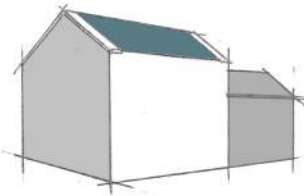

Long

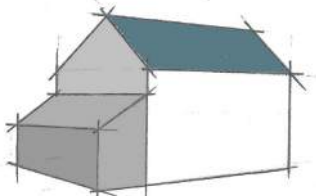

Lean to

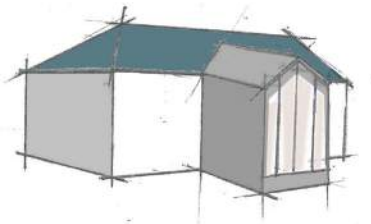

'T' rear extension

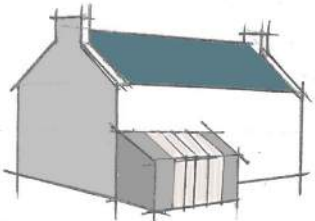

Rear lean to extension with large openings

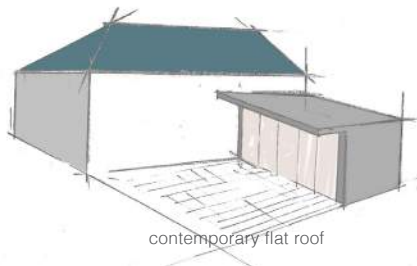

contemporary flat roof

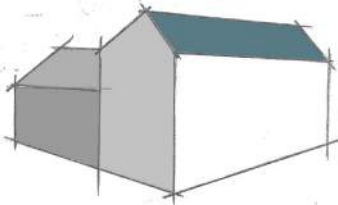

Cross gabled

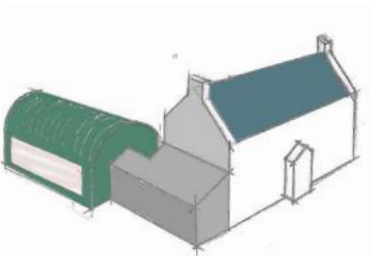

Extension linking to converted outbuilding

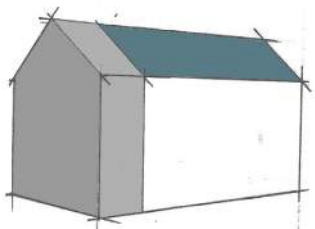

Long extension

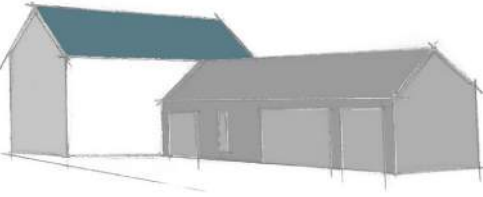

'L' shape pitched roof

*  = Extension

CONVERSIONS

Proposals for the conversion or reinstatement of existing buildings of substance in the countryside that are deemed worthy of retention by the Council will be considered favourably, providing they satisfy the following criteria:

- The original walls must be substantially intact. Buildings of a ruinous nature will not be appropriate.
- Buildings should be of local, visual or historical interest and be constructed in traditional materials to justify retention and conservation;
- Buildings must be physically capable of undergoing conversion and their original appearance must be substantially retained. A structural survey by a chartered engineer must be submitted as part of a planning application.
- Works must be executed in a sensitive manner and retain architecturally important features whenever possible and make use of existing buildings and traditional and complementary building materials, techniques and specifications;



Stable conversion. Newcastle, County Wicklow.



Restoration potential of cottage and outbuildings. Tinahely, County Wicklow.



05 APPENDICES



ACKNOWLEDGEMENTS

Written by: Sorcha Walsh

Designed by: Paul Conlon

Special Thanks: Aisling MacNamara

Stephen Willoughby

Bernadette Harvey

Lucy Roche

Sketches, illustrations, photos and graphic design (unless otherwise noted) by Paul Conlon

Special gratitude to all who kindly granted the use of material for their inclusion in this document.

All rights reserved. The content of this document may not be reproduced or adapted without the consent of the author(s).

PHOTO & DESIGN ACCREDITATIONS

01 Ballygonnell

02 Carraignamweel House, Henchion+Reuter

03 Glenealy

04 Out of the Blue. Mosart

05 Brittas Bay. House7

06 Cottage in Wicklow. StudioRed

07 Arklow, Wicklow. Brian Donovan

08 Rural form, Wicklow. Emmet Duggan

09 House Slievebawnogue. Clancy Moore

10 S House, Enniskerry. FKL

11 Cottage in Wicklow. StudioRed

12 Ty Gwyn, Dunbur, Wicklow. IDS

13 Tornant House, Dunlavin. Wicklow

14 Sweet Briar, Bray

15 Pavillion, Enniskerry. Buckley Partnership

16 Blake House, Blessington. Michael Kelly

17 Blake House, Blessington. Michael Kelly

18 Carraignamweel House. Henchion+Reuter

19 Stone wall, Ballinaclash, Wicklow

20 Splayed entrance, Wicklow

21 Mounded entrance, Wicklow

22 Timber fencing, Wicklow

23 Maytree. ODOS

24 Out of the Blue. Mosart

25 Farmhouse, Roundwood. C Corlett.

26 Stone outbuilding, Wicklow

27 Retrofit, Wicklow. Renova

28 White's barn, Clonmannon. Chris Southgate

29 Wicklow mountains, Calzean

30 Carraignamweel House. Henchion+Reuter

31 Cottage refurbishment, Wicklow. D Bannon

32 Small extension Aughtrim. Gerrard Hynes

33 Farm House, Manor Kilbride. Philip O'Reilly

34 Leabeg House, Newcastle. Bernard J Burke

35 Cottage Knockatomcoyle, Tinahely

36 Cow House Blessington. Michael Kelly



Wicklow County Council

**County Buildings,
Whitegates, Wicklow Town
A67 FW96**

Phone: 0404-20148

Fax: 0404-69462

Email: plandev@wicklowcoco.ie